

FEATURES :

- 4PIN SIP & 8PIN DIL Package
- High Efficiency up to 85%.
- Unregulated Output Types
- Single Output 3.3/5/9/12/15V Approved By UL60950-1
- Internal SMD Construction
- No External Component Required
- Operating Temperature:-40°C TO +85°C
- Industry Standard Pinout

Specifications typical at TA=25°C, nominal input voltage and rated output current unless otherwise specified

Part Number	Output Voltage	Output Current	Efficiency	Package Style
	Vdc	mA	%TYP	"X"
★11D-XXS03NNL	3.3	76	65	1
★11D-XXS05NNL	5	50	65	1
★11D-XXS09NNL	9	28	67	1
★11D-XXS12NNL	12	21	70	1
★11D-XXS15NNL	15	16	70	1
★11D-XXS24NNL	24	10	70	1
11D-XXS03NXNL	3.3	76	65	2/3/4/5
11D-XXS05NXNL	5	50	65	2/3/4/5
11D-XXS09NXNL	9	28	70	2/3/4/5
11D-XXS12NXNL	12	21	70	2/3/4/5
11D-XXS15NXNL	15	16	70	2/3/4
11D-XXS24NXNL	24	10	70	2/3/4
11D-XXD03NXNL	±3.3	±38	65	2/3
11D-XXD05NXNL	±5	±25	65	2/3
11D-XXD09NXNL	±9	±14	70	2/3
11D-XXD12NXNL	±12	±10	70	2/3
11D-XXD15NXNL	±15	±8	70	2/3
11D-XXD24NXNL	±24	±5	70	2/3

Note :

- 1."XX" Is Input Voltage:03=3.3Vdc,05=5Vdc,09=9Vdc, 12=12Vdc, 15=15Vdc,24=24Vdc
- 2.Over 15V,24V input voltage using the 1/2/3/4 Package.
- 3.The input voltage increases, there will be an increase in efficiency.
4. " ★ " marked as recognized by UL 60950-1.

Input Specifications

Parameters	Conditions	Min	Typ	Max	Units
Voltage Tolerance	Vo,Io Nom			±5	%
Filter	Capacitor				



DC-DC Converter

11D SERIES

0.25Watt

1KV Isolated

Single & Dual Output

SIP4 & DIL8

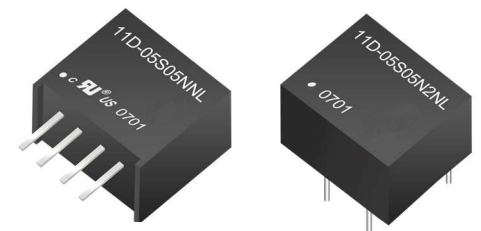

Temperature Derating Graph

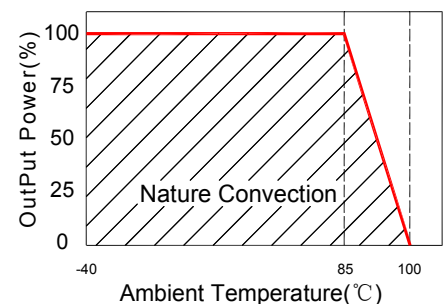

Output Specifications

Parameters	Conditions	Min	Typ	Max	Units
Voltage Tolerance	100% full load			±5	%
Short Circuit Protection	Short Term			1	Sec
Line Regulation	For 1.0% OF Vin		1.2		%
Load Regulation	3.3V,5V (10% To 100% F.L)			15	%
Load Regulation	9V,12V,15V,24V (10% To 100% F.L)			10	%
Ripple & Noise	BW=DC To 20MHz			100	mVp-p
Transient response setting time	50% load step change		350		us

General Specifications

Parameters	Conditions	Min	Typ	Max	Units
Isolation Resistance	500Vdc	1000			MΩ
Switching Frequency	Full load, nominal input		100		KHz
Operating Temperature		-40		+85	°C
Humidity	Non Condensing			95	%
Cooling	Free air Convection				
Case material	DAP				
MTBF	MIL-HDBK-217F @25°C	3500000			Hours
Weight	Package 1/2/3/4/5	1.5/1.5/1.9/1.9/1.1			g
Dimensions	Package 1	11.50x6.00x10.00			mm
Dimensions	Package 2	12.70x10.16x6.80			mm
Dimensions	Package 3	12.70x10.16x7.50			mm
Dimensions	Package 4	11.50x7.50x10.00			mm
Dimensions	Package 5	11.50x6.00x7.50			mm

Tolerance Envelope Graph

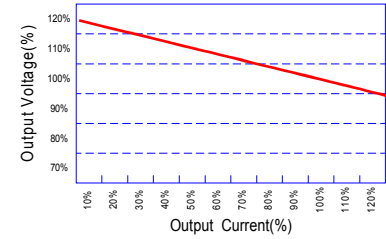

Part Number

11D - 05 S 05 N 2 NL
A B C D E F G

- A:Series
- B:Input Voltage
- C:Single(S)Dual(D)
- D:Output Voltage
- E:Unregulated(N)
- F:Package
- G:RoHS Version

Recommended Test Circuit

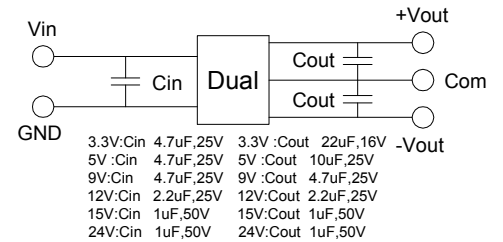
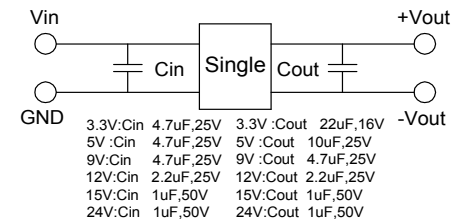

Markings and Dimensions

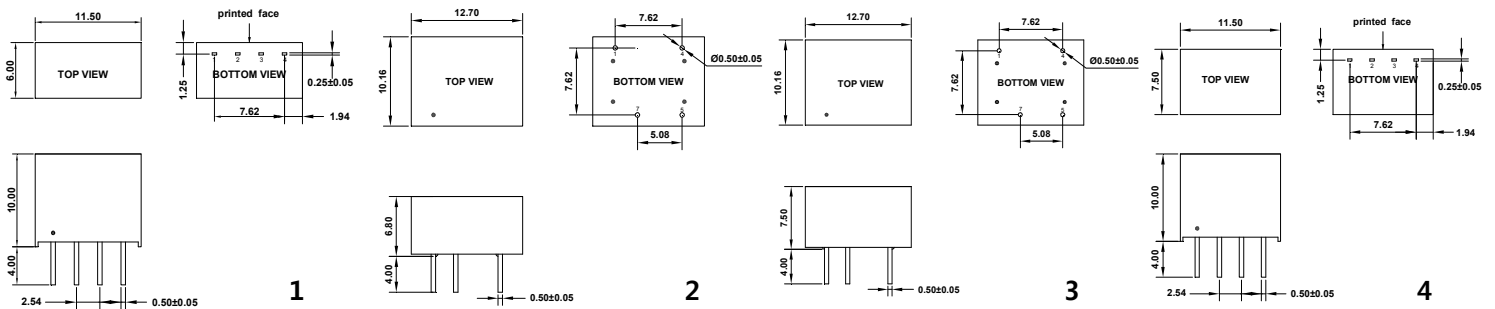

Unit:mm Unless otherwise specified, all tolerances are ±0.25

PIN Connection

PIN	1	2	3	4	5	6	7	8
Single(4Pin)	-Vin	+Vin	-Vout	+Vout				
Single(8Pin)	-Vin	No Pin	No Pin	+Vin	+Vout	No Pin	-Vout	NC
Dual(8Pin)	-Vin	No Pin	No Pin	+Vin	+Vout	No Pin	Com	-Vout

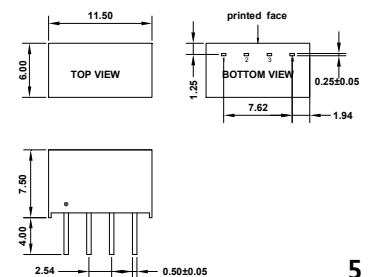

5

FEATURES :

- Small Footprint
- 14PIN SMD Package
- High Efficiency up to 72%
- Unregulated Output Types
- High Power Density
- No External Component Required
- Operating Temperature:-40°C TO +85°C
- Industry Standard Pinout



Specifications typical at TA=25°C, nominal input voltage and rated output current unless otherwise specified

Part Number	Output Voltage	Output Current	Efficiency
	Vdc	mA	%TYP
13DS-03S03N0.25W	3.3	76	65
13DS-03S05N0.25W	5	50	65
13DS-03S09N0.25W	9	28	70
13DS-03S12N0.25W	12	21	72
13DS-03S15N0.25W	15	16	72
13DS-05S03N0.25W	3.3	76	65
13DS-05S05N0.25W	5	50	65
13DS-05S09N0.25W	9	28	70
13DS-05S12N0.25W	12	21	72
13DS-05S15N0.25W	15	16	72
13DS-09S03N0.25W	3.3	76	65
13DS-09S05N0.25W	5	50	65
13DS-09S09N0.25W	9	28	70
13DS-09S12N0.25W	12	21	72
13DS-09S15N0.25W	15	16	72
13DS-12S03N0.25W	3.3	76	65
13DS-12S05N0.25W	5	50	65
13DS-12S09N0.25W	9	28	70
13DS-12S12N0.25W	12	21	72
13DS-12S15N0.25W	15	16	72
13DS-15S03N0.25W	3.3	76	65
13DS-15S05N0.25W	5	50	65
13DS-15S09N0.25W	9	28	70
13DS-15S12N0.25W	12	21	72
13DS-15S15N0.25W	15	16	72

Input Specifications

Parameters	Conditions	Min	Typ	Max	Units
Voltage Tolerance	Vo, Io Nom			±10	%
Filter	Capacitor				

DC-DC Converter

13DS-0.25W SERIES

0.25Watt

1KV Isolated

Single Output

SMD

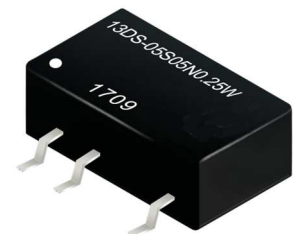

Temperature Derating Graph

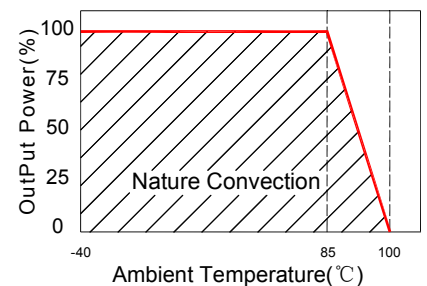

Output Specifications

Parameters	Conditions	Min	Typ	Max	Units
Voltage Tolerance	100% full load			±5	%
Short Circuit Protection	Short Term			1	Sec
Line Regulation	For 1.0% OF Vin		1.2		%
Load Regulation	3.3V (10% To 100% F.L)		15		%
Load Regulation	5V,9V (10% To 100% F.L)			15&9.0	%
Load Regulation	12V,15 V (10% To 100% F.L)			7.5&7.0	%
Ripple & Noise	BW=DC To 20MHz			100	mVp-p
Transient response setting	50% load step change		350		us

General Specifications

Parameters	Conditions	Min	Typ	Max	Units
Isolation Resistance	500Vdc	1000			MΩ
Switching Frequency	Full load, nominal input		100		KHz
Operating Temperature		-40		+85	°C
Humidity	Non Condensing			95	%
Cooling	Free air Convection				
Case material	DAP				
MTBF	MIL-HDBK-217F @25°C	3500000			Hours
Weight			1.2		g
Dimensions			12.7x7.6x6.25		mm

Markings and dimensions

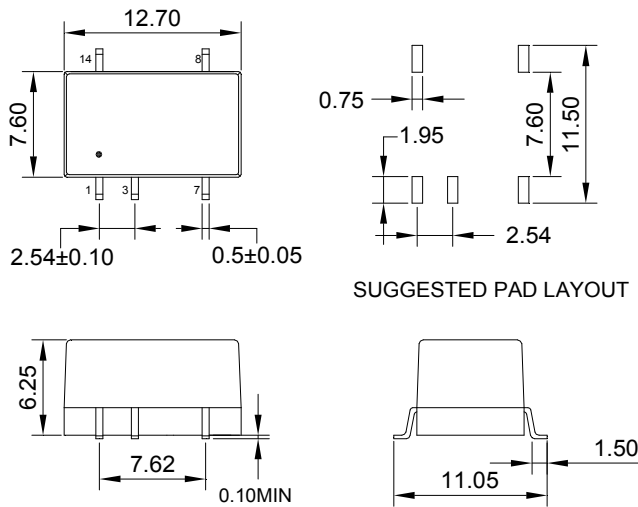

UNIT:mm Unless otherwise specified,all tolerances are ±0.25

Tolerance Envelope Graph

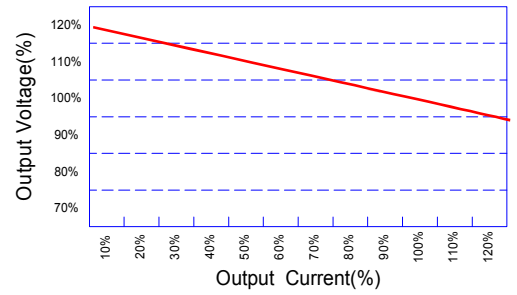

Part Number

13DS - 05 S 05 N 0.25
A B C D E F

- A:Series
- B:Input Voltage
- C:Single Output
- D:Output Voltage
- E:Unregulated(N)
- F:Output Power

Recommended Test Circuit

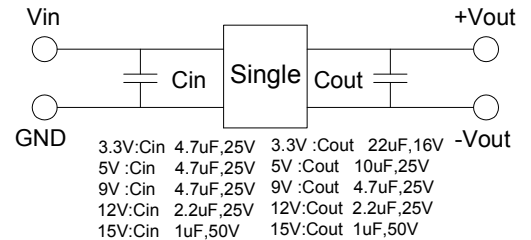

PIN Connection

PIN	1	3	7	8	14
Single	-Vin	+Vin	-Vout	+Vout	NC